

PART

ORIO-0040-J01

検討・見積り 依頼

図面配布日: 2021.03.22

配布図面No.24289

見積り数量: 年600枚(50個/月)

見積り期限: 3/25

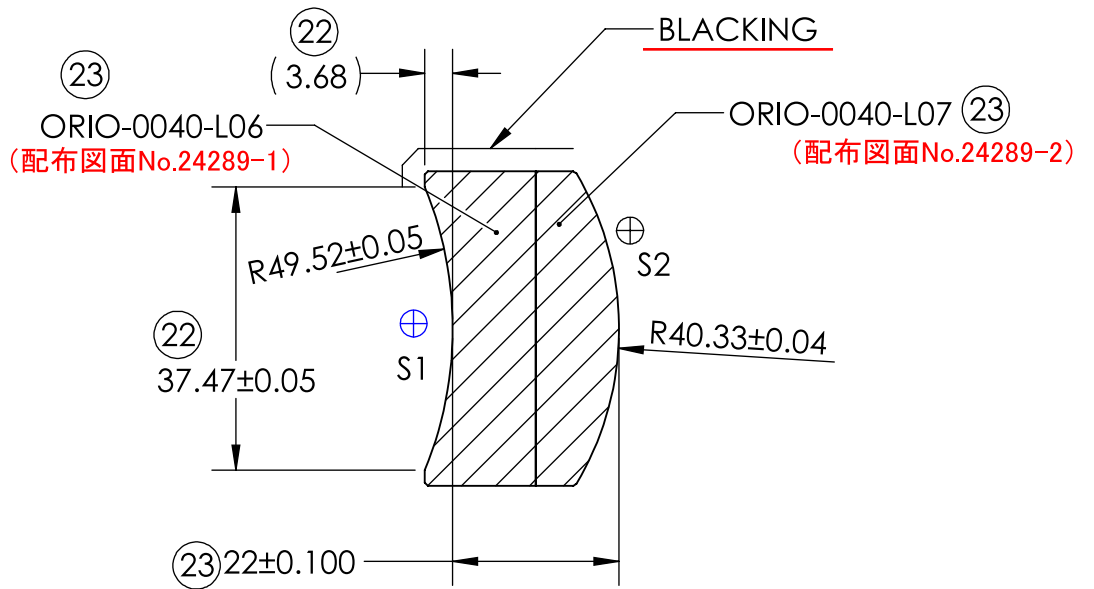
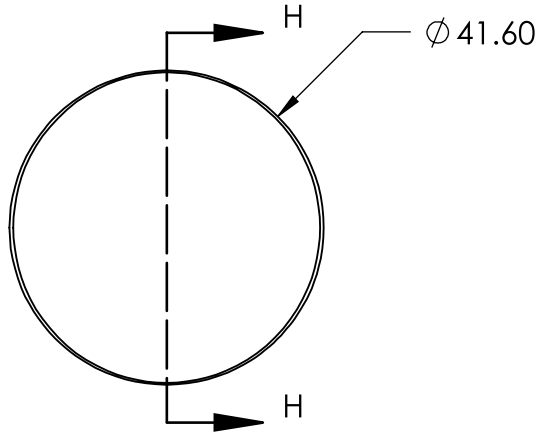

SECTION H-H
SCALE 1 : 1

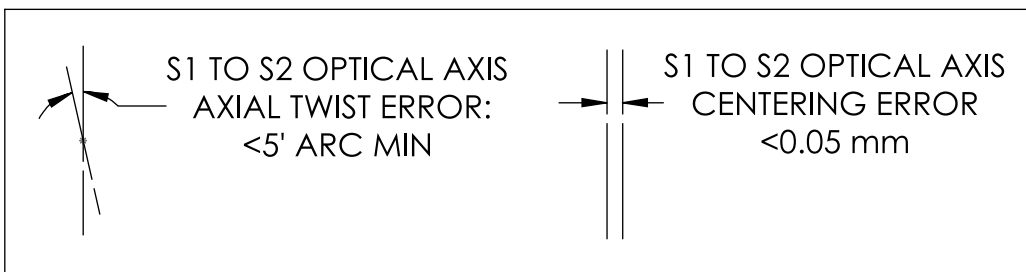
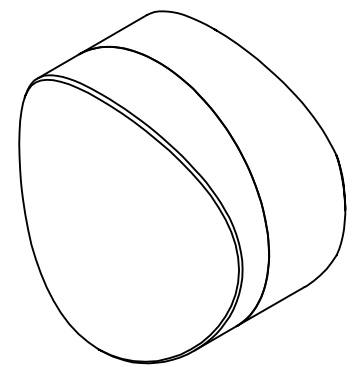
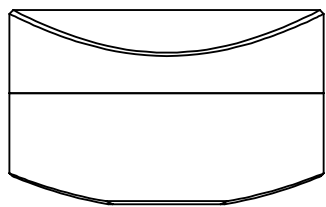

NOTES:

1. MgF2 COATING - WAVELENGTH: 600nm ±25nm
2. EDGE BLACKING - PAINT MUST BE FLAT AND WITHOUT VISUAL DEFECTS
3. EXAMINE INSIDE EDGES OF ELEMENT WITH 70W FLUORESCENT LAMP

.025/
Rz

ALL DIMENSIONS IN MM

ORIO-0040-J01		
SPECIFICATION		
MATERIAL	H-LAF3B	H-ZK9B
SURFACE	S1	S2
FRINGES	3	3
ΔN	.5	.5
S.Q.	60-40	60-40
C.A.	90%	90%
CENTERING	5'	
CHIP	NO CHIP	

DIMENSIONAL VALUES	PART DESCRIPTION	
	ALL DIMENSIONS IN MM .025/ Rz	REAR CYL DOUBLET
PART NUMBER ORIO-0040-J01		DRAWN DATE 6/21/2019
		REV 23
	SCALE: 2:1	Sheet 1 of 1